



VEX<sup>100</sup>

VEX<sup>200</sup>

VEX<sup>200</sup>

USER GUIDE

ver. 10

# Table of contents

---

- **Disclaimer of Product and Services** ..... 3
- **Warnings and Precautions** ..... 4
- **Warranty** ..... 5
- **Introduction**..... 6
- **Overview** ..... 7
- **Control Panel VKEY100/200/200+** ..... 11
- **User guide**..... 11
  - How to connect Keyboard VKey-100 & 200/200+ ..... 12
  - to the Reckeen system..... 12
  - Test and calibration of the V-Key 100/200/200+ keyboard..... 11
  - Calibration of Joystick and T-Bar ..... 12
  - adjusting the brightness of the keyboard's backlight ..... 14
  - How to use v-key100/200 keyboard ..... 15
- **Specification** ..... 27
  - Keyboard VKey-100 & 200/200+ specification ..... 28

# Disclaimer of Product and Services

This manual and the software described herein, in whole or in part, may not be reproduced, translated, or reduced to any machine-readable form without prior written approval. Reckeen provides no warranty with regard to this manual, the software, or other information contained herein and hereby expressly disclaims any implied warranties or merchantability or fitness for any particular purpose with regard to this manual, the software, or such other information. In no event shall Reckeen be liable for any incidental, consequential, or special damages, whether based on tort, contract, or otherwise, arising out of or in connection with this manual, the software, or other information contained herein or the use thereof. In the manual, the ™ or ® marks are not specified. Reckeen reserves the right to make any modification to this manual or the information contained herein at any time without notice. The information provided in this manual is intended only as guide. All the time, Reckeen will try to give correct, complete and relevant information. However, Reckeen can't exclude that some of the information contained in this manual, from time to time, may not be correct or may be incomplete. This manual may contain omissions, typographical errors or incorrect information. Reckeen always recommends that you carefully check the information given in this manual for accuracy before making any purchase decision or using the product. Reckeen is not responsible for any errors or omissions, or for any subsequent loss or damage resulting from the use of the information contained within this manual. For further guidance on the content of this manual or on the product contact your local Reckeen Office or dealer.

The software described herein is governed by the terms of a separate user license agreement. Reckeen is not liable and will not compensate for any lost recordings or streamings made to your Reckeen 3D STUDIO or LITE, external recording media, or recording devices or any relevant losses, including when recordings are not made due to reasons including your Reckeen 3D STUDIO or LITE failure, or when the contents of a recording are lost or damaged as a result of your Reckeen 3D STUDIO or LITE failure or repair undertaken to your Reckeen 3D STUDIO or LITE. Reckeen will not restore, recover, or replicate the recorded or streamed contents made to your Reckeen 3D STUDIO or LITE, external recording media, or recording devices under any circumstances.

# Warnings and Precautions

1. Read carefully all of these warnings and save them for later reference.
2. Follow all warnings and instructions marked on this unit.
3. Unplug this unit from the wall outlet before cleaning. Do not use liquid or aerosol cleaners. Use a damp cloth for cleaning.
4. Do not place this unit on an unstable cart, stand, or table. The unit may fall, causing serious damage.
5. Do not use this unit in or near water.
6. Slots and openings on the cabinet top, back, and bottom are provided for ventilation. To ensure safe and reliable operation of this unit, and to protect it from overheating, do not block or cover these openings. Do not place this unit on a bed, sofa, rug, or similar surface, as the ventilation openings on the bottom of the cabinet will be blocked. This unit should never be placed near or over a heat register or radiator. This unit should not be placed in a built-in installation unless proper ventilation is provided.
7. This product should only be operated from the type of power source indicated on the marking label of the AC adapter. If you are not sure of the type of power available, consult your dealer or your local power company.
8. Do not allow anything to rest on the power cord. Do not locate this unit where the power cord will be walked on, rolled over, or otherwise stressed.
9. If an extension cord must be used with this unit, make sure that the total of the ampere ratings on the products plugged into the extension cord do not exceed the extension cord's rating.
10. Make sure that the total amperes of all the units that are plugged into a single wall outlet do not exceed 15 amperes.
11. Never push objects of any kind into this unit through the cabinet ventilation slots, as they may touch dangerous voltage points or short out parts that could result in a risk of fire or electric shock. Never spill liquid of any kind onto or into this unit.
12. Except as specifically explained elsewhere in this manual, do not attempt to service this product yourself. Opening or removing covers that are marked "Do Not Remove" may expose you to dangerous voltage points or other risks, and will void your warranty. Refer all service issues to qualified service personnel.
13. Unplug this product from the wall outlet and refer to qualified service personnel under the following conditions:
  - When the power cord is damaged or frayed;
  - When a liquid has spilled into the unit;
  - When the product has been exposed to rain or water;
  - When the product does not operate normally under normal operating conditions. Adjust only those controls that are covered by the operating instructions in this manual; improper adjustment of other controls may result in damage to the unit and may often require extensive work by a qualified technician to restore the unit to normal operation;
  - When the product has been dropped or the cabinet has been damaged;
  - When the product exhibits a distinct change in performance, indicating a need for service.

# Warranty

For a period of one year from the original date of purchase of the product, Reckeen equipment is guaranteed against any manufacturing defects. The original purchase receipt or invoice or other documentary evidence is required. To obtain warranty service, you must deliver the product, in either its original packaging or packaging affording an equal degree of protection. You cover all mail, delivery, transportation and insurance costs. It is your responsibility to backup any data, software or other materials you may have stored or preserved on your unit. It is likely that such data, software, or other materials will be lost or reformatted during service and Reckeen will not be responsible for any such damage or loss. Our warranty doesn't cover damage caused by accidents or unauthorized modifications, installing any other software and repairs, misuse, sand, grit or water. All other claims of any nature are not covered by this warranty. This Warranty is valid only in the country of purchase. REPAIR OR REPLACEMENT AS PROVIDED UNDER THIS WARRANTY IS THE EXCLUSIVE REMEDY OF THE CONSUMER. RECKEEN SHALL NOT BE LIABLE FOR ANY INCIDENTAL OR CONSEQUENTIAL DAMAGES FOR BREACH OF ANY EXPRESS OR IMPLIED WARRANTY ON THIS PRODUCT. EXCEPT TO THE EXTENT PROHIBITED BY APPLICABLE LAW, ANY IMPLIED WARRANTY OF MERCHANTABILITY OR FITNESS FOR A PARTICULAR PURPOSE ON THIS PRODUCT IS LIMITED IN DURATION TO THE DURATION OF THIS WARRANTY. Accessories, such as the battery or the cable, are excluded from the warranty. These terms do not affect your statutory rights.

# Introduction

Until recently, the use of virtual studio technique has been available only for the major TV networks, due to its high costs. With development of computers and digital image processing techniques, now such solutions are becoming more and more common. Nowadays, they can be used not only by the major TV stations, but also by local stations, educational institutions (e.g. to create educational programs), as well as by various companies and organizations, e.g. for products' presentation or preparation of staff trainings, promotional or educational materials, etc.

Thus, the Reckeen 3D Studio product was created in order to meet the needs of this market segment. It is characterized by a very good price performance ratio paired with a simplified interface, which allows the operators to learn its usage very easily.

The Reckeen 3D Studio system is a ready to use solution - the user receives a complete workstation along with the preinstalled software and additional input/output cards mounted. The Reckeen 3D Studio enables connecting four cameras (4xHDMI or 2xHDMI and 2xSDI depending on version) and keying the signal. Instead of camera, we can connect every video signal source e.g. laptops, tablets, video players and other computing devices.

# Overview

The Reckeen 3D Studio is a PC-based system of a complete virtual 3D studio with the ability to import files in OBJ, 3MF and FBX formats and also available to prepare or download internal file formats \*.recSets. In this case content is protected from modification and copying.

It is a system that enables a real time production of video programs with a high quality chroma key.

The Reckeen 3D Studio system uses four cameras in Full HD mode up to 60 frames per second and their images are keyed independently. The application allows you to work in 4K resolution. This means operating the system's up to 2 inputs and 1 output in 2160p format, i.e. with a resolution of 3840x2160 p30 or p 60. The chroma and luma key also work in 4K format. The system has 4 virtual cameras with the capability to save up to 15 shots for each of them. This allows the operator to use the following virtual camera movements in the scenography: pan, tilt, zoom, dolly, truck, arc, pedestal, cant and others.

Virtual cameras are controlled via the control panel Reckeen VKey100- specially dedicated to the system and equipped with a joystick.

Thanks to the built-in camera editor, you can program very impressive virtual camera movements and transitions in the 3D scenography, and with an innovative 3D set design editor Wizard installed on your system, you can modify and create your own unique studio designs.

This unique 3D scenography editor allows us to build "from scratch" our own 3D studio with available objects. The user as if he built blocks, builds his own scenography and then can modify the color, structure of the studio elements and many other properties. At the end, you can also set your own stage lighting by choosing the type of light , intensity and color.

Thanks to access to Microsoft Paint 3D we get the possibility to put into our scenography objects created with this program e.g. 3D subtitles.

The Reckeen 3D Studio system has a built-in STILL Editor for creating captions, text panels or news tickers - even during the Production.

In addition, the Reckeen 3D Studio system with four inputs for cameras and four chroma keys allows the user to place even four talents (a talent is an image of a presenter or an actor in front of a camera) on a single scenography.

It can also be used in a situation, where the images are transmitted by four cameras from different locations just to be placed in a single virtual scenography. The Reckeen 3D Studio system includes tools for recording, producing and online streaming the created live program. Reckeen can also be launched in LITE mode. In this situation , system deliver the tools for the creation scenography without 3d spatial knowledge. User can build as much more easier views based on pictures and images.

## CONTROL PANEL VKEY 100, 200, 200+

The VKey 200 control panel stands for ergonomics, high performance, premium craftsmanship and style. Reckeen VKey200 Control Panel – Precise control over real-time video operations for professional use.



Reckeen VKey100 Control Panel – Precise control over real-time video operations for professional use.

With Reckeen VKey 100, you can have control over multiple functions of the Reckeen 3D or LITE Studio. We have designed it to be operators' working environment friendly, functional, modern and reliable, but also to be affordable. Our control panel combines ergonomic design, top-quality precise mechanics and versatile functionality. Its main features are:

- Power Supply 12V / 500mA - Safe power supply voltage
- Communication interface RS232 - To connect to the Reckeen Studio system
- Joystick and T-bar calibration functions - These functions allow precise calibration of both handles at any time
- Adjustable brightness of the buttons - Precise control over brightness for maximum user comfort
- Joystick XYZ (3-axis) - With this multifunctional joystick you can precisely manipulate the virtual cameras' movements in a virtual space
- Comfortable T-bar Fader - With a contactless Hall Effect technology using magnetic sensor and angle measurement. A smooth consistent feel is achieved by utilizing Teflon bearing surfaces and steel ball races
- Mechanical adjustment of the T-bar resistance - It ensures a smooth and precise forward and backward movement of the T-bar handle
- Buttons backlight function test - Users can perform the test themselves
- 107 LED illuminated button - 107 LED illuminated buttons for heightened visibility of control surface activity.



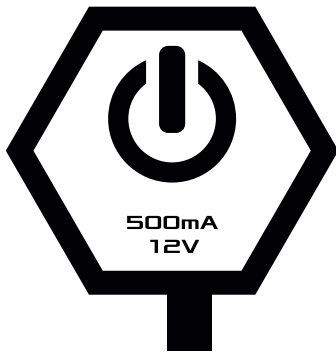

Power Supply 12V / 500mA - safe power supply voltage.

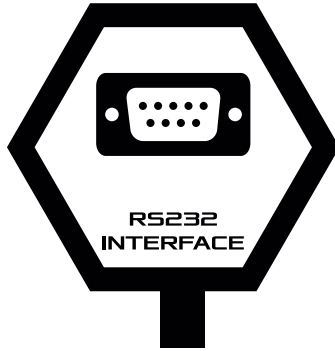

Communication interface RS232 - to connect to the Reckeen Studio system.

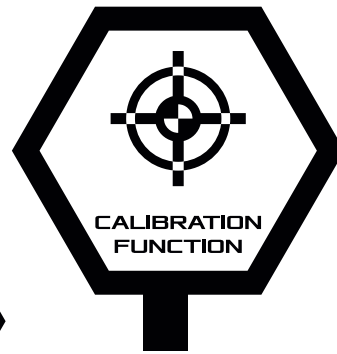

Joystick and T-bar calibration functions - these functions allow precise calibration of both handles at any time.

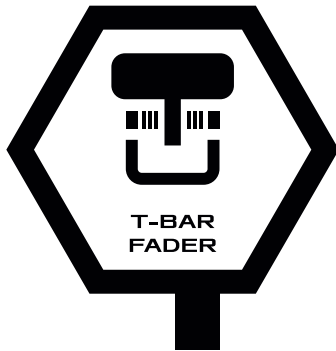

Comfortable T-bar Fader - with a contactless Hall Effect technology using magnetic sensor and angle measurement. A smooth consistent feel is achieved by utilizing Teflon bearing surfaces and steel ball races.



Buttons backlight function test - users can perform the test themselves.

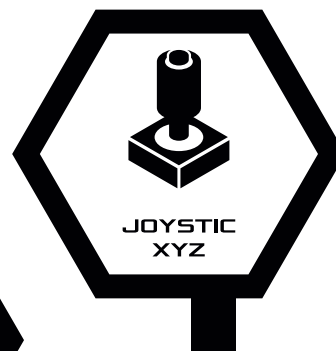

Joystick XYZ (3-axis) - with this multifunctional joystick you can precisely manipulate the virtual cameras' movements in a virtual space.



Adjustable brightness of the buttons - precise control over brightness for maximum user comfort.



107 LED illuminated buttons for heightened visibility of control surface activity.

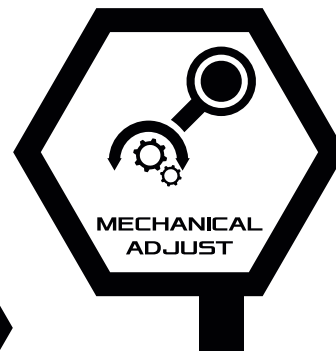

Mechanical adjustment of the T-bar resistance - it ensures a smooth and precise forward and backward movement of the T-bar handle.

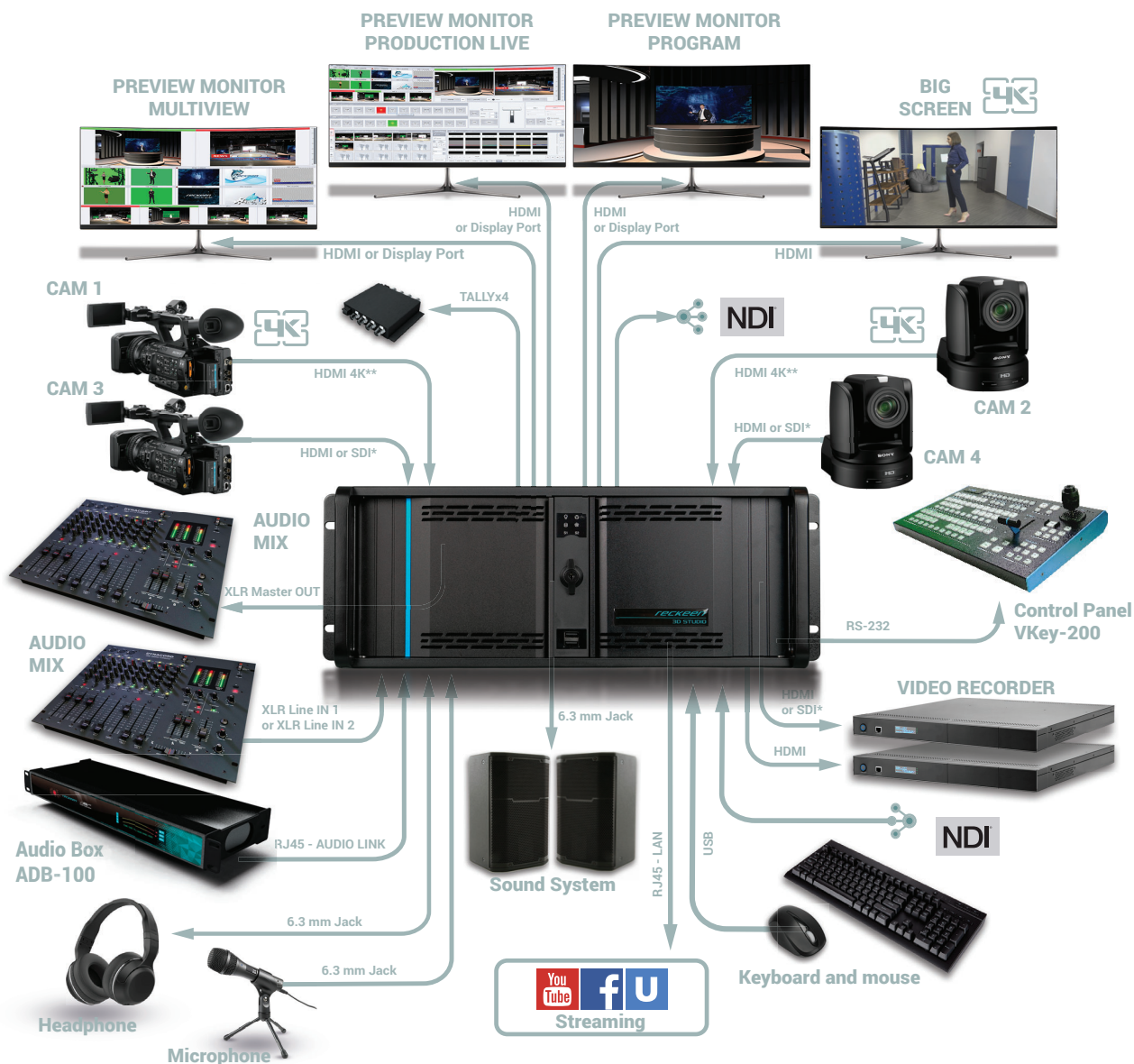



2

Control Panel  
VKEY100/200/200+  
User guide

You can control the Reckeen 3D system with the VKey-100 & 200 control panel, or/and with a standard PC keyboard.

## HOW TO CONNECT KEYBOARD VKEY-100 & 200/200+ TO THE RECKEEN SYSTEM

The full set of configurations includes:

- Vkey100/200/200+ Control panel
- RS 232 communication cable with DB9 connector.
- Power supply unit and adapterst



Connect the keyboard to the system using RS 232 communication cable with DB9 connector. Plug the end of the cable to the input / output card. Connect the other end of the cable to the keyboard's port. Screw in the locking screws. Picture below.



It is also possible to connect the Vkey100/200/200+ via a **USB** connector. For this you need an external USB to RS232 converter, it is not included in the set.

If you choose this type of keyboard connection, you must first configure the RS port in your system. Choose tab [Option / Configuration / General / External Keyboard Settings](#):

In this window, a list of available Com ports will appear in your system. Indicate the correct port to which your Vkey100/200/200+ keyboard is connected (**Available serial port for the keyboard**). Confirm by pressing option: **Change serial port**.

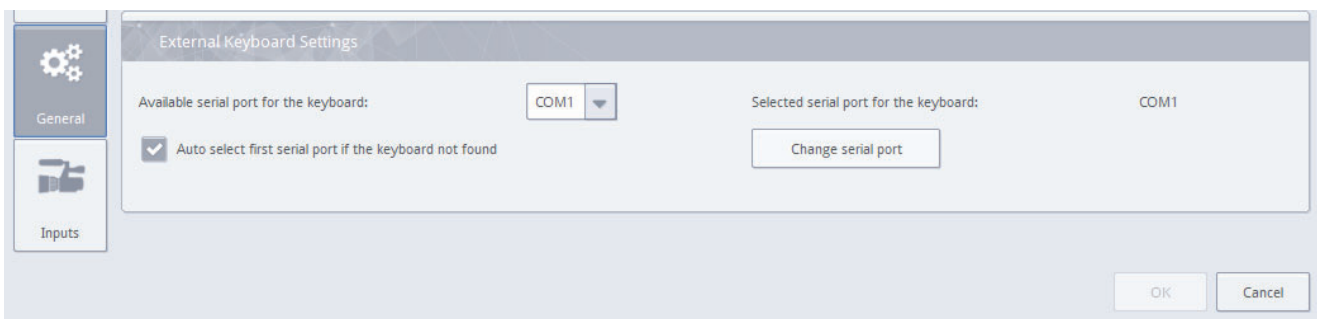

Function of automatically searching the port is also available. If the Vkey keyboard has not been found by manual selection, you can enable the function - **"Auto select first serial port if the keyboard not found"**.

Use a proper power supply adapter used in different types of electrical networks. Select the appropriate adapter and insert it into the power plug. Move it forward until you hear a click. Picture below.



First connect the power supply plug to the VKey 100 / 200 keyboard power socket and bolt the locking screw. Picture below.



Next connect the power supply unit to the electrical outlet. Picture below



Now you can safely set the Reckeen system switch to position 1 and then turn on the power using the VKey 100 switch.



## TEST AND CALIBRATION OF THE V-KEY 100/200/200+ KEYBOARD

In the first step, turn the keyboard on by switching the power button to position 1. The appropriate buttons will light up for a moment.

In order to perform the keys' illumination test, a proper sequence has to be performed. The following buttons have to be pressed simultaneously: DELEGATION A, DELEGATION DSK 1 and LOCK like the picture below.



After this action, the LOCK and DELEGATION DSK 1 buttons are blinking. It is now possible to check the backlight of all buttons. Let's press the keyboard keys one by one, in any order. The first time you press a key, it lights up in white. A second press makes the key light up in its function color: red, green or orange - depending on its application. Picture below.



You can exit the test mode by pressing LOCK key. The keyboard will return to its normal operation mode.

## CALIBRATION OF JOYSTICK AND T-BAR

Simultaneously press the following buttons: DELEGATION A , DELEGATION DSK 2 and and LOCK like the picture below.



5 buttons will light up signaling execution of a test for example, communication F1. Picture below.



The second test is JOYSTICK's calibration. Move it to the right and to the left to its extreme positions. When it's completed, the F2 LED will light up in white. Picture below.



Now let's move the joystick up and down to its extreme positions. When you complete that, the F3 LED will light up in white. Picture below.





F4 is the JOYSTICK's knob calibration. We turn it several times to the right and to the left to the extreme positions. When you complete that, the F4 LED will light up in white. Picture below.



F5 test is the T-BAR's calibration. Move the T-BAR to its extreme positions. Picture below.

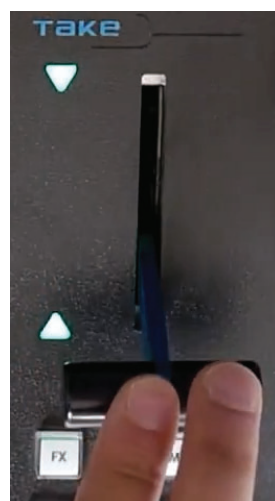

After several movements, all the LEDs will go out. This way, the keyboard has been calibrated and has returned to its normal operation mode.

## ADJUSTING THE BRIGHTNESS OF THE KEYBOARD'S BACKLIGHT

Simultaneously press the following buttons: DELEGATION A, DELEGATION B and LOCK like picture bellow.



The keyboard shows the current brightness of the keys. Pressing TAKE key several times decreases the backlight's brightness. AUTO key increases brightness of the keys. Picture below

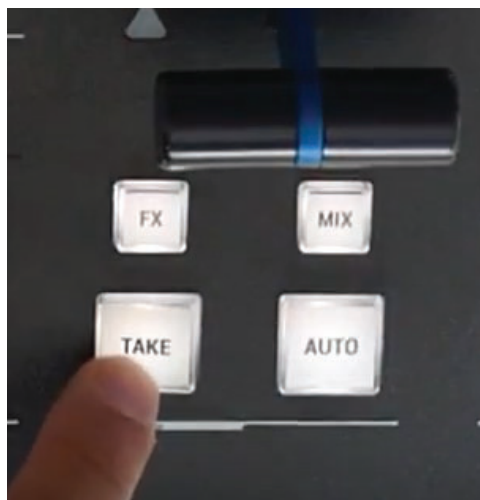

When an appropriate value is set, exit the mode by pressing LOCK key. The keyboard returns to its normal operation mode.

## HOW TO USE V-KEY100/200 KEYBOARD

Control Pane: Picture below:

Vkey 200/200+



Vkey100



In the central part you can find a main mixer. The first row of buttons, backlit in red, stands for PROGRAM channel, live on-air.

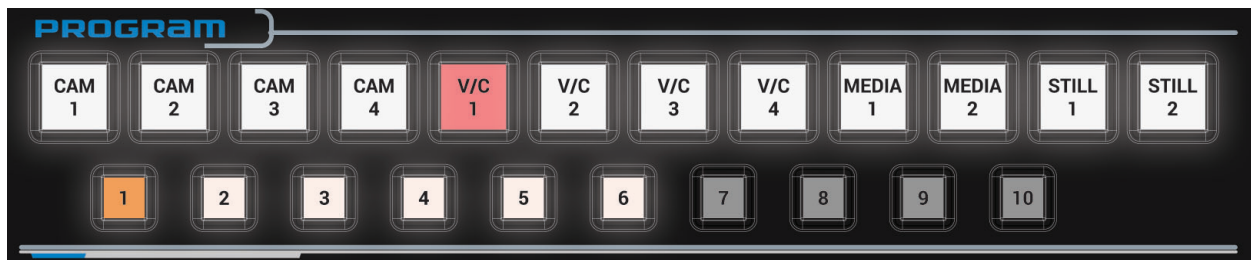

The second row of buttons is the PREVIEW channel, where you prepare the the content that will go on-air next. It is backlit in green.

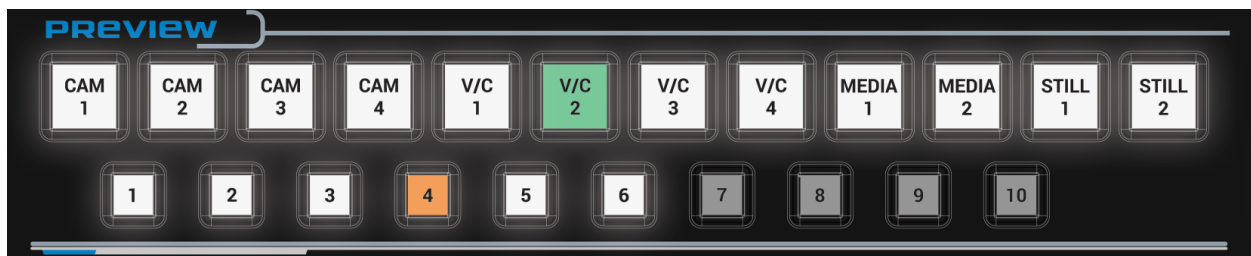

State of the keyboard keys reflects the state of the Reckeen application.

A transition between video channels can be performed with TAKE function. This is an immediate transition. In this case, the selected items on the Program and Preview mixers switch their places.

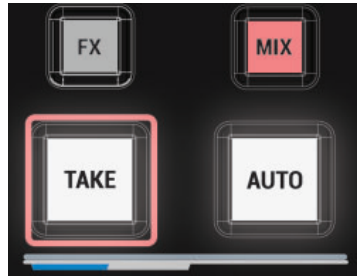

The second method is a transition with the use of AUTO. It is a smooth transition with a time set in the application. After its use, the T-BAR's motion is reflected in the application. And a smooth change between

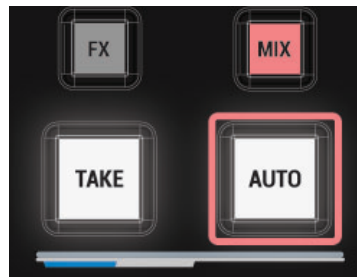

PROGRAM and PREVIEW channels takes place.

The third option is to use the T-BAR manually. A lit up green arrow indicates that the T-BAR is in its extreme position. After moving to the opposite extreme position, the arrow on the opposite side will light up. The PREVIEW channel will smoothly transition to the PROGRAM channel.

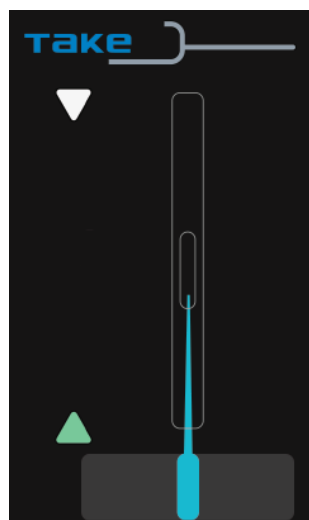

You can control the camera shots using the V/C buttons. It is possible to highlight shots in the application after selecting an appropriate video channel. Press a button, for example PROGRAM channel's V/C 1.



In the application, V/C 1 tab will be highlighted in red.

PROGRAM channel shots will appear next to it. There are 15 possible shots in a given V/C, first 10 of which can be found on the keyboard.



In the default NEWS studio, 6 shots have been programmed, so the same number of buttons is currently backlit on the keyboard in the PROGRAM shots section. After pressing one of the buttons, a virtual camera makes a transition to a given shot in accordance with an application mode set, e.g. linear or curved at the speed of 5. A smooth transition to the next point is made. After this movement, the button lights up permanently in orange.

The same can be done in the PREVIEW channel. Let's press one of the V/C buttons.



In the application, the tab will change its color to green.



In the window, you can see PREVIEW channel shots. Press one of the buttons to change the shot. The camera moves, this time in the PREVIEW channel. After this movement, the button lights up permanently in orange.

Next think you can configure are the signal sources in the virtual studio. In the application, the ABCD mixer is used for that purpose.



On the keyboard, the DELEGATION BUS keys will be used.

Vkey 100

Vkey 200/200+

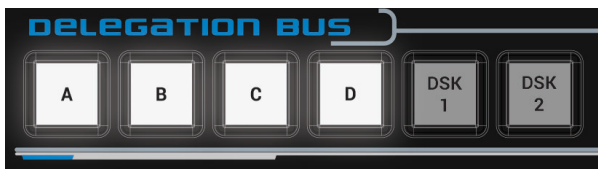

Hold down one of the delegation button, for example A. Buttons with the available source selection for layer A will be illuminated in the PREVIEW channel.

Note: access to delegation E to H or DSK2 in VKey 200 require pressing Shift button first.

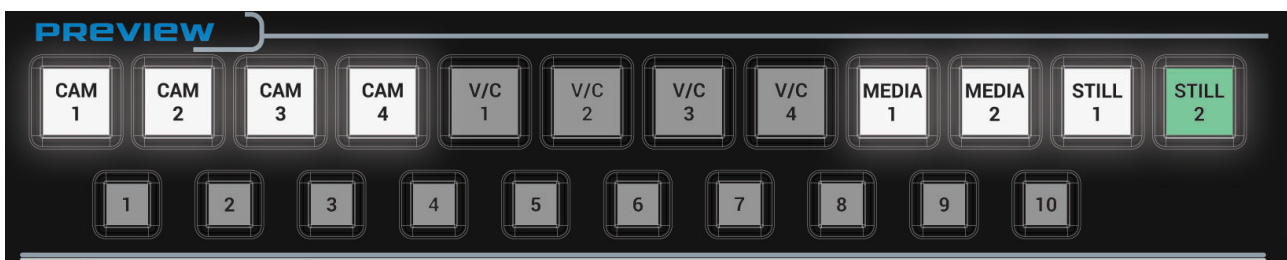

Note: Delegation E to H are not yet supported by the Reckeen application.

In addition, you can use the buttons on the media mixer.

VKey 100

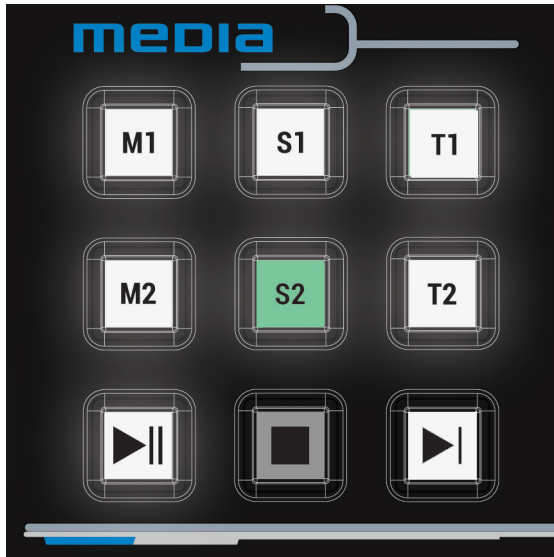

VKey 200+



When you select one of the buttons, the selection will appear in the application's ABCD mixer. Right next to ABCD delegation buttons, you can find buttons for setting up the sources for DSK layers.

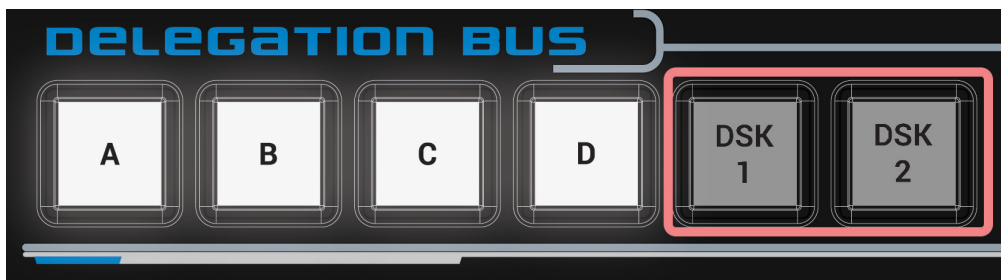

They are inactive, so first you have to enable one of the layers. Let's press a button, e.g. DSK 1.

Note: access to delegation DSK2 in VKey 200/200+ require pressing Shift button first.

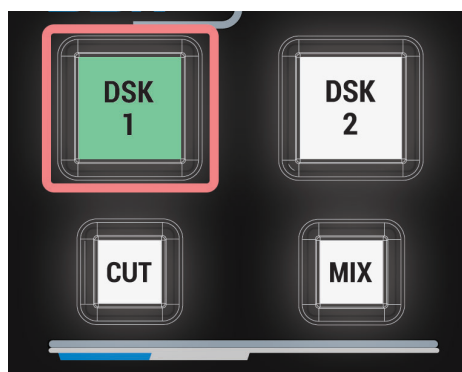

It will be backlit in green, which means - visible in the PREVIEW channel. Now the DELEGATION BUS button is active. Hold down one of the Delegation BUS buttons, e.g. DSK 1. This time you choose a source for DSK 1 in the PREVIEW channel. You can also use the media mixer. Pressing the button brings the keyboard to its normal operation mode.

Operating the DSK with the keyboard is synonymous to using the application. It is possible to redirect a DSK source from PREVIEW to PROGRAM channel using CUT button.

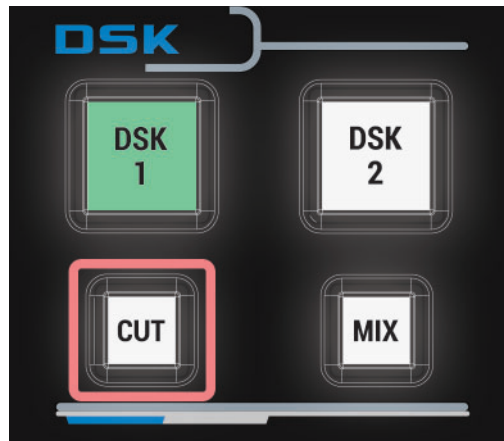

After pressing it, the source will immediately appear on-air. DSK 1 button lights up in red. DELEGATION DSK buttons are turned off. Another way to introduce a DSK source on air is to use MIX button.

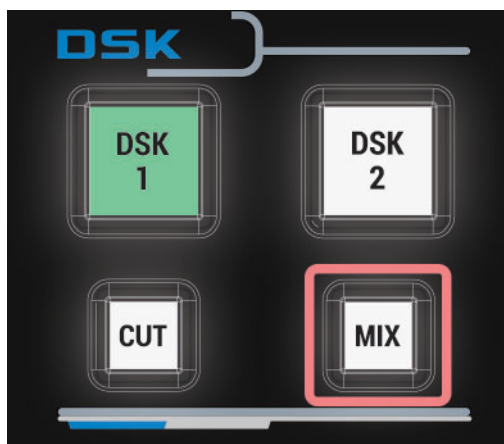

When a proper time is set in the application, the source will appear by a smooth transition from the PREVIEW to the PROGRAM channel.

There are three OUTPUT buttons next to DELEGATION buttons.

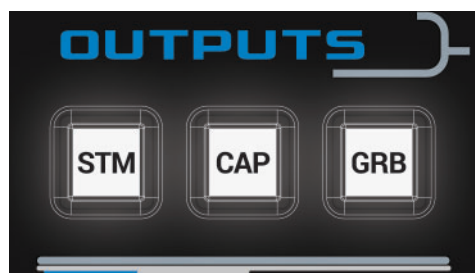

The first one - CAPTURE - allows you to record the PROGRAM channel to a video file on the PC disk. When pressed, it will light up in red. The recording starts and a corresponding button with a timer becomes highlighted in the application. The recording is stopped by pressing CAPTURE button again. The button is



backlit in white until its next use. Similarly, you can use STM button to stream to a server. Next to it, you can see GRB button for creating a graphic image of the program output.

There are 10 function keys in the upper part of the keyboard. If they are not backlit in white, it means that none of these buttons have been programmed.



You can program them by going to MENU OPTIONS and CONFIGURATION. In the TRIGGER tab, you can assign them suitable functions, e.g. GRAPHICS OVERLAY. After programming two buttons, F1 and F3 for example, and exiting the configuration window, these programmed function keys will be backlit on the VKEY keyboard.



After pressing F1 key, it lights up in red as active. All the others are disabled. The function's deactivation occurs after pressing this button again. After switching it off, the programmed keys will light up in white.

It is possible to control a virtual camera with a JOYSTICK, both in the preview channel and on air.



On the PROGRAM mixer, select a button, [V/C 1](#) for example.



The corresponding tab will be highlighted in red in the application. In the Joystick control section, select **V/C** mode, which will enable control of this virtual camera on the Program Output using the joystick.



There are three options below.

- The first one is MOVE. When you select this button, it lights up in orange.



With the JOYSTICK you can move the camera forwards, backwards, to the right and to the left.

The three F M S buttons are used to set virtual camera speed. S stands for SLOW, M for MEDIUM, and F

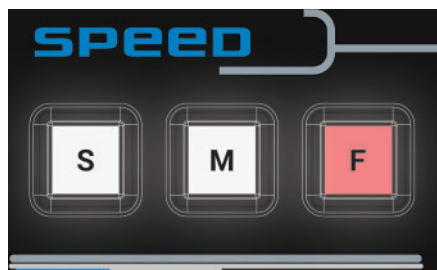

for FAST speed. The speed mode reacts with JOYSTICK's movements and rotations.

Rotating the joystick to the right raises the virtual camera position and rotating to the left lowers the virtual camera position.

- ROTATION is the second option for moving the camera.



Using the JOYSTICK you can rotate the camera around its own axis (right, left, up and down). Using the knob in this mode, you move the camera forward by turning the knob to the right and backwards by turning it to the left.

- The third movement option is ORBIT.



In this mode, you move the camera around a specific point in the studio with a fixed distance from it. By default, this is the 0.0 point. The point of orbit center can be changed in the CAMERA SETUP. Choose a new point for virtual camera orbiting by selecting and highlighting an object. After leaving the CAMERA SETUP editor, the new center point of the orbit will be remembered.



When you select a DSK option and its source, you can set the position of the DSK content on the screen with the JOYSTICK. If the DSK button is backlit in green, then the button is active and can be selected.

VKey 100 / 200

VKey 200+



Note: delegation DSK2 in VKey 200/200+ require pressing Shift button first.

access to



There are two options at your disposal.

- The first - positioning of DSK source.



With a JOYSTICK you can, for example, insert a picture, such as a logo, anywhere in the PREVIEW screen. Use the JOYSTICK's rotation to scale it. Reduce its size by turning the joystick to the right and enlarge it by turning to the left. Move the joystick up, down, right and left to change the content's position on the screen.



If the DSK layer is transferred to the PROGRAM channel, then making adjustments with a JOYSTICK is no longer possible.

- There is also a second option to use a JOYSTICK for DSK. Choose DSK and ROTATION option.



By rotating the joystick, you can rotate the DSK content to the right or to the left respectively.



You can find a LOCK button next to the Joystick. It allows you to completely lock the JOYSTICK. When it lights up in red, the JOYSTICK is protected against accidental use.

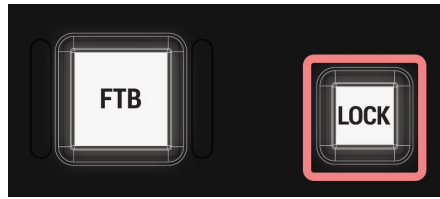

In emergency situations, it is possible to press the FTB button which will then light up in red. A black board will appear on the PROGRAM screen and the sound on the mixer will be muted. Pressing this button again restores the previous view and the sound mixer's state.



With the keyboard, you also have control over video and image trays. With a single button, e.g. M1, you can select MEDIA 1 video tray in the application.

VKey 100/200

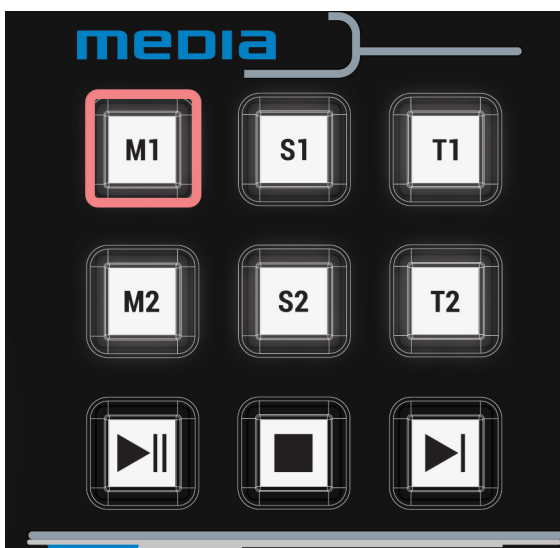

Vkey 200+



Note: access to delegation M3, M4 in VKey 200+ require pressing Shift button first. M3 & 4 are not yet supported in the Reckeen application.

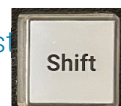

It will automatically open MEDIA 1 video tray in the application and will highlight previously chosen file. Stop the media playback by pressing STOP button.



Start the playback with PLAY button. When it is playing, you can PAUSE it with the same button as well.



Press NEXT button to select the next file from the tray.



It will be highlighted in the window as ready to use. You open a new file by pressing PLAY button. In the same way, you can view STILL and TEXT image files or play a playlist sequence.

Vkey 200+ control panel has a dedicated key **PTZ** that indicates the active assignment of the joystick function to the PTZ camera. This key is highlighted in blue.



**Note:** Control Panel VKey 200/200+ has additional keys: CAM 5 to CAM 8, MEDIA 3, MEDIA 4, VSE 1, VSE 2 - these are not supported in Reckeen 3D Studio V3.1 or earlier software, and have future intended use in subsequent versions of the software.



3

Specification

## KEYBOARD VKEY-100 & 200/200+ SPECIFICATION

### Communication Interface

- RS-232 , external cables USB-RS adapter

### Baud Rate

- 38400

### Power

- DC12V

### Power Consumption

- 12 W

### Working Temperature

- 0°C ~ +40°C

### Storage Temperature

- -20 °C ~ +60°C

### Relative Humidity

- < 90% (non-condensation)

### Net Weight

- Vkey 100 - 2,850 kg , Vkey 200 & 200+ - 3,300 kg

### Accessories

- RS-232 Transmission Cable
- DC In power Adapter

### Vkey Accessory List:

No	Item	Qty
1	Vkey 200 or Vkey 200+ unit	1
2	DC 12V power adapter	1
3	USB stick user manual	1
4	RS cable	1



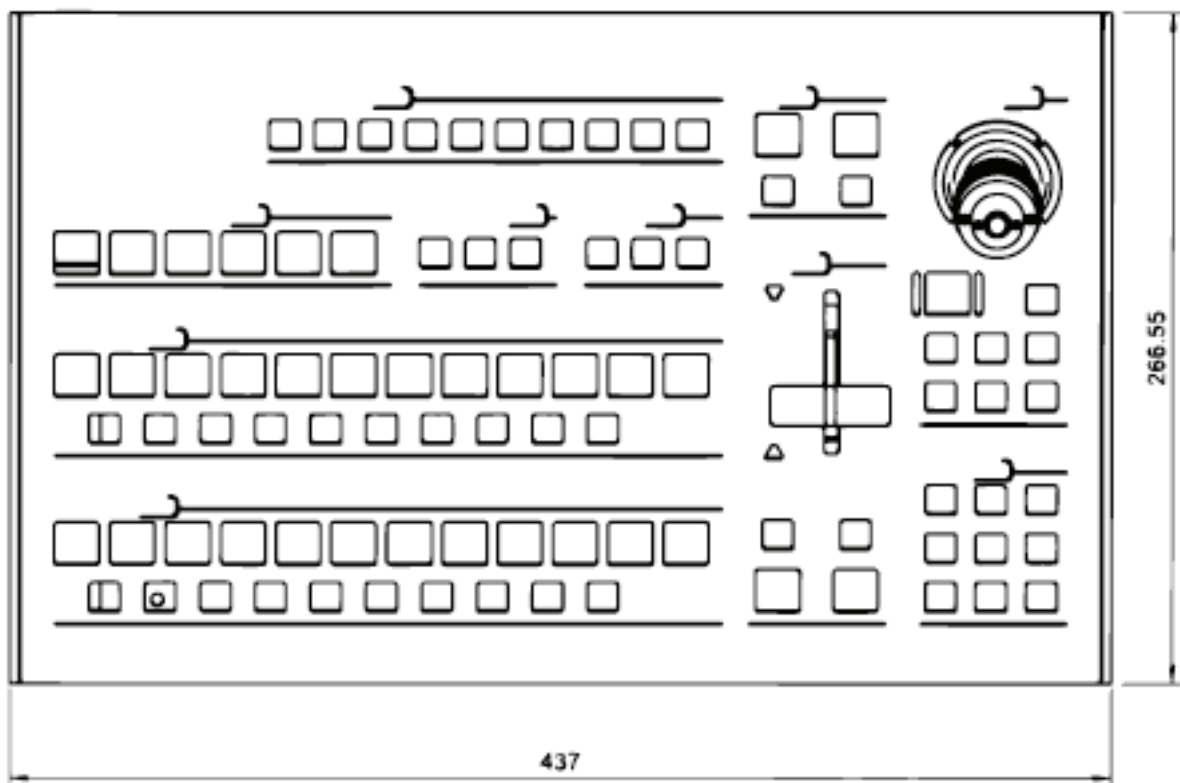
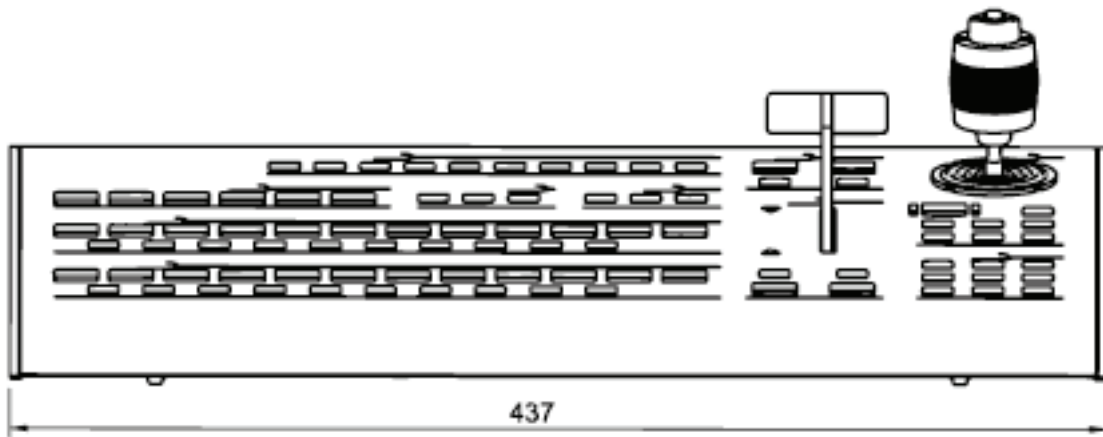
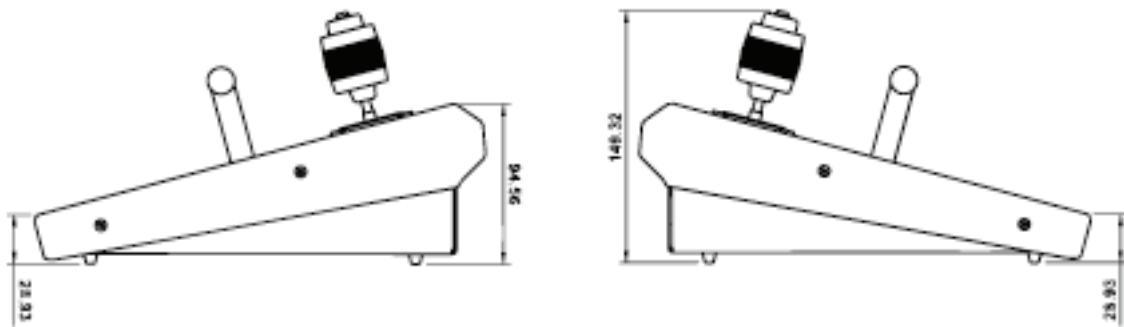

All measurements in millimetres (mm)



© **Copyright 2017- 2024 Reckeen.**

All rights reserved. 'Reckeen' is registered trademark.

All other company and product names may be trade marks of their respective companies with which they are associated.